

# Molecular Basis of Mammalian Embryonic Stem Cell Pluripotency and Self-Renewal

S. P. Medvedev<sup>1,2</sup>, A. I. Shevchenko<sup>1,2</sup>, S. M. Zakian<sup>1,2,3\*</sup>

<sup>1</sup> Institute of Cytology and Genetics, Siberian Branch, Russian Academy of Sciences

<sup>2</sup> Institute of Chemical Biology and Fundamental Medicine, Siberian Branch, Russian Academy of Sciences

<sup>3</sup> Research Center of Clinical and Experimental Medicine, Siberian Branch, Russian Academy of Medical Sciences

\* E-mail: zakian@bionet.nsc.ru

Received 28.07.2010

**ABSTRACT** Mammalian embryonic stem cells (ESC) have a number of specific properties that make them a unique object of fundamental and applied studies. In culture, ESC can remain in an infinitely undifferentiated state and differentiate into descendants of all three germ layers – ectoderm, endoderm, and mesoderm – that is, they can potentially produce more than 200 cell types comprising the body of an adult mammal. These properties of ESC are referred to as self-renewal and pluripotency. In this review, the basic signal pathways implicated in the maintenance of ESC pluripotency are considered. The major genes comprising a subsystem of “internal regulators of pluripotency,” their protein products and regulators, are characterized, and interaction with other factors is described as well. The role of epigenetic mechanisms and microRNAs in the system of ESC self-renewal and pluripotency, as well as the relationship between pluripotency and X-chromosome inactivation in female mammals, is discussed.

**KEYWORDS:** embryonic stem cells, pluripotency, transcription factors, X-chromosome inactivation

**ABBREVIATIONS:** ESC – embryonic stem cell, mESC – murine ESC, hESC – human ESC, TSC – trophoblast stem cell, iPSC – induced pluripotent stem cell, ICM – inner cell mass, HCNE – highly conserved non-coding element

## MAMMALIAN EMBRYOGENESIS AND STEM CELLS. PLURIPOTENT CELLS *in vivo* AND *in vitro*

Development of any mammal begins from a single cell, called the zygote. Its successive division and differentiation of daughter cells eventually results in the formation of an organism composed of more than 200 cell types, each executing a specific function via the formation of tissues and organs in which different cell types interact with each other. These functional, biochemical, and physiological specificities of distinct cell types depend on the characteristic pattern of gene expression. All the diverse forms of RNA transcribed in the cell nucleus are called “transcriptome,” which (unlike genome) is distinctive of the cell type and differs in different cell types within the body. The cell transcriptome is determined by a tight interaction between the genetic and epigenetic systems. The former includes transcription factors, the proteins modulating expression of target genes at the transcription level. The latter includes proteins providing differential gene transcription via the changing and maintenance of the chromatin structure by a chemical modification of the DNA in promoter regions, particularly the 5'-methylation of cytosines in CpG islets, and methylation and acetylation of histones, amongst other modifications. Regulation of gene transcription also involves the microRNAs

(miRNAs) controlling gene expression at the posttranscriptional level [1].

Detached cell types, the so-called stem cells, are present at different stages of mammalian ontogenesis. These cells are characterized by a unique transcriptome and a complex of genetic and epigenetic components allowing self-renewal; i.e., sustaining the stem status for a short or long time (depending on the stem cell type) and maintaining the capability of differentiation into various secondary cell types [2]. Stem cells may be subdivided into several subtypes, depending on how wide the daughter cell type spectrum is [2].

Totipotent cells can differentiate into all the possible cell types that a mature mammalian body consists of. These cells are also implicated in the formation of extraembryonic tissues and organs, particularly placenta. In mammals, the only totipotent cells are the zygote and early cleavage stage blastomers.

Pluripotent cells can differentiate into descendants of all three germ layers: ectoderm, mesoderm, and endoderm. During ontogenesis, pluripotent cells can form a mature mammal body. However, they cannot produce extraembryonic tissues and organs. Pluripotent cells are in the inner cell mass and epiblast of mammal embryos, as well as their descendants, embryonic stem cells growing *in vitro*. Besides, embryonic germ cells that

originate from gamete precursors and epiblast stem cells isolated from postimplantation mouse embryos are also pluripotent [3–5]. In recent years, methods allowing to make mature differentiated cells pluripotent by the introduction of exogenous factors have been developed. These cell types are called induced pluripotent stem cells (iPSCs). To date, iPSC lines of human, mouse, and some other mammals have been isolated [6–8].

Multipotent cells are region-specific stem cells (those of a mature body, which are located among differentiated cells of various tissues) that can differentiate into several cell types. Examples of such cells are hematopoietic stem cells differentiating into blood cells.

Unipotent cells are precursors of only one cell type. For instance, spermatogonial stem cells are precursors of male gametes.

As already mentioned, mammalian embryo blastomeres are totipotent up to an eight-cell stage. Each blastomer of an 8-cell embryo possesses the potential to form all possible cell types, including the cells comprising extraembryonic organs. This property of mammalian blastomeres was confirmed in experiments on the construction of aggregation chimeras. However, a transition to the 16-cell stage (morula) is associated with the first differentiation event. Each of the eight blastomeres undergoes either a symmetrical division to form two polar outer cells of morula or an asymmetrical division to form a polar outer cell and a nonpolar, relatively small, cell localized within the embryo. Thus, the fourth division of zygote produces an embryo composed of two first-specialized cell groups: the outer polar and the inner nonpolar cells [9]. Following the next two-cell divisions, the outer polar cells of morula form the outer cell layer called trophoblast. It is required for the implantation of the embryo into the uterine endometrium and formation of placenta. The trophoblastic cells form a sphere with the inner cavity, the blastocoel. The inner nonpolar cells of the morula are transformed into the embryo inner cell mass (ICM) located at one end of the blastocyst on the inner side of the trophoblastic layer. Preceding implantation into the uterus, ICM is divided into two layers: the epiblast (primitive embryonic ectoderm) and the hypoblast (primitive embryonic endoderm). Throughout the course of its development, the epiblast gives rise to the embryo body (all tissues and organs), whereas the hypoblast forms the yolk sac. Thus, the mammalian preimplantation embryo (blastocyst) is composed of three compartments: the trophoblast, the hypoblast, and the epiblast, two of which (trophoblast and hypoblast) produce extraembryonic tissues and organs and one that forms all the fetal tissues during further development [10]. The structure of preimplantation embryos is very similar in different mammalian species. The blastocysts of primates closely

resemble those of rodents, featuring a greater number of cells and morphology after implantation. However, despite their similar structures, the blastocysts of primates differ from those of rodents in the time of compartmentation (into the trophoblast, hypoblast, and epiblast) and are characterized by a longer preimplantation development (7–10 days in primates compared with four days in mice) [11].

All three compartments of preimplantation embryos (the epiblast, trophoblast, and hypoblast) are sources of stable stem cell lines called embryonic stem cells, trophoblast stem cells, and extraembryonic stem cells, respectively. Cultured stem cells keep most of the features characteristic of their precursors, such as the gene expression pattern, epigenetic features, and many biochemical and physiological parameters. The stem status and correspondence of cell lines to their precursors existing *in vivo* is best demonstrated by injecting the cells into a recipient blastocyst. After ESC injection, both TSC and extraembryonic ectodermal cells become involved in embryogenesis, contributing to the formation of the corresponding embryonic or extraembryonic tissues and organs. All three cell types isolated from preimplantation embryos require specific culture conditions, such as the medium composition and presence of growth factors, in order to maintain their stem status. Sometimes, co-cultivation is necessary with other cell types synthesizing the factors required for maintenance of the undifferentiated state of stem cells [12–18].

Embryonic stem cells that possess self-renewal and pluripotency features are of particular interest. Self-renewal implies the capability of infinite symmetrical division leading to the appearance of two pluripotent cells. As mentioned above, pluripotency is the capability of a stem cell to differentiate into cell derivatives of all three germ layers, but not extraembryonic tissues. Pluripotency is the characteristic that makes ESC a unique model for the investigation of the processes underlying cell differentiation and opens a broad avenue for ESC use in fundamental research into biological events at early stages of mammalian ontogenesis, including chromosome X inactivation, epigenetic genome changes, etc. Moreover, ESCs have practical use. Their unique features can be used in trials of novel drugs and studies of the toxicity of chemical substances. ESCs are a prominent source of biological material for cell replacement therapy in human diseases, although the issue of how safe they are remains unsettled and under study.

At the moment, the focus of studies of ESC self-renewal and pluripotency is on their molecular basis. To date, it is known that a complex system of cell-surface proteins, their molecular signaling pathways, and the

transcription factors initiating or modulating target gene transcription sustain the pluripotency of pre-implantation embryo cells and ESCs. Several signaling cascades/pathways are implicated in maintaining pluripotency. These pathways constitute an external pluripotency regulation subsystem. A considerable body of experimental data suggests that this subsystem is not conservative. In particular, some signaling molecules, such as LIF and BMP4, have opposite effects on the self-renewal of mouse and human ESCs [19–21].

In addition to the subsystem of external regulators of pluripotency, there is a subsystem of internal regulators which includes three transcription factors: OCT4, SOX2, and NANOG. These factors have a broad spectrum of target genes in murine and human ESCs, and their effect, unlike that of signaling pathways, is exclusively directed toward maintaining self-renewal and pluripotency in various mammals [22, 23].

Recent data suggest a tight link between the two subsystems in ensuring a stable functioning of the entire system that sustains self-renewal and pluripotency [24] (Fig. 1). The subsystems have also proved to interact with proteins comprising the system of epigenetic regulation of gene expression (Polycomb and other proteins) and with miRNAs specific for ESCs or various differentiated cell descendants.

**SIGNALING CASCADES TRIGGERED BY INTERLEUKIN LIF**

Initially, murine ESC lines were obtained using either mitotically inactivated fetal fibroblasts forming a feeder layer or a conditioned medium in which teratocarcinoma cells or fetal fibroblasts were preliminarily grown for a given amount of time [12, 13]. Mouse ESC culturing without a feeder layer or in an unconditioned medium resulted in cell differentiation. The nature of the agent secreted by fetal fibroblasts and required for sustaining the undifferentiated state of ESCs was determined later: the agent was interleukin LIF (Leukemia Inhibitory Factor), a member of the IL-6 family [25]. The recombinant LIF protein is currently widely used to isolate and culture mouse ESCs, in order to avoid the use of both a feeder and conditioned medium [26, 27]. The LIF protein, via interaction with a heterodimeric receptor LIFRβ-gp130 localized on the cell membrane, can activate three signaling cascades: JAK (tyrosine kinase Janus)-STAT3 (signal transducer and activator of transcription-3), the PI3K (phosphatidylinositol 3-kinase)-mediated pathway, and the MAPK (mitogen-activated protein kinase) cascade. Only JAK-STAT3 is activated solely by LIF, whereas the other two cascades are triggered by multiple molecular signals [24].

In the JAK-STAT3 cascade, LIF is the initial molecular signal that activates the transcription factor

**Fig. 1.** System of “external and internal regulators of pluripotency” in human ESC. Signal molecules and receptors on the cell plasmatic membrane are indicated by dark circles and blue rectangles, respectively. Gray, red, and green ovals indicate molecules involved in signal transmission from receptors to the cell’s nucleus and regulation of gene expression, together with the transcription factors OCT4, SOX2, and NANOG in the cell’s nucleus. Arrows represent activation and stoppers – repression as well and activity of SMAD1/5/8 which induces hESC differentiation.

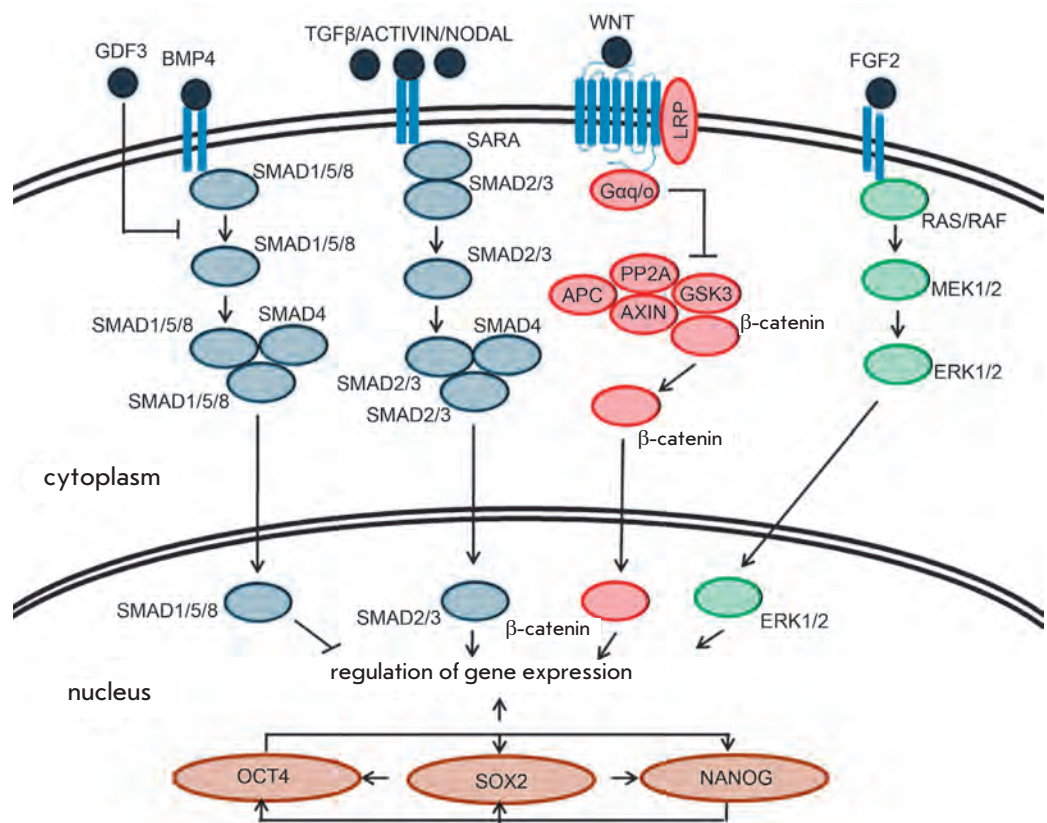

STAT3. Its binding with the LIFRβ-gp130 receptor causes the activation of phosphoprotein kinases. Both the Janus tyrosine kinase and immunoreactive phosphotyrosine kinase phosphorylate the tyrosine residues of the cytoplasmic part of the LIFRβ-gp130 heterodimer. The transcription factor STAT3 binds to the phosphotyrosine residues of the activated LIFRβ-gp130 heterodimer and undergoes subsequent phosphorylation and dimerization. Phosphorylated STAT3 dimers are transported into the cell nucleus, where they interact with the target genes [25, 28].

The important role of the LIF-STAT3 signaling pathway in sustaining the self-renewal of murine ESCs has been convincingly shown [29]. On the other hand, abundant data suggest a LIF-STAT3-independent mechanism sustaining ESC pluripotency in humans and other primates [21, 30].

Up until recently, not much data was available regarding the mechanisms of LIF implication in the maintenance of murine ESC pluripotency. Recent data provided by Niwa and colleagues [24] suggests the integration of LIF-triggered molecular cascades into the subsystem of internal regulators of pluripotency, whose components are the genes *Oct4*, *Sox2*, and *Nanog* (Fig. 1). This integration takes place via two pathways: JAK-STAT3 and PI3K-mediated. STAT3 activates the expression of KLF4 (Krüppel-like factor 4), which, in turn, is a positive regulator of the *Sox2* gene. In parallel, the PI3K signaling cascade activates a gene encoding another transcription factor, TBX3, which then activates the *Nanog* gene. Moreover, inhibitors of MAPK that mediate the third, LIF-activated signaling cascade cause the accumulation of the TBX protein in the cell's nucleus and the activation of the *Tbx3* and *Nanog* genes (Fig. 2). Moreover, LIF can indirectly (via MAPK) activate TBX3 transport (Fig. 2), but this pathway seems to be inhibited by some third factor.

**TGFβ/ACTIVIN/NODAL, BMP, AND BFGF (FGF2) SIGNALING PATHWAYS**

The TGFβ (transforming growth factor-β) superfamily includes a large number of signaling molecules (about 40 putative protein ligands of TGFβ are found in humans). This superfamily may be subdivided into two large groups of activators:

1) TGFβ/ACTIVIN/NODAL activating the transcription of SMAD2/3 (similar to mothers against decapentaplegic homologue) transcription factor genes via receptors of ALK4 (activin-like kinase 4), ALK5, and ALK7;

2) BMP (bone morphogenic protein)/GDF (growth differentiation factor) activating SMAD1/5 via the receptors of ALK1, ALK2, ALK3, and ALK6. Also, two proteins of the SMAD family are inhibitors of the same

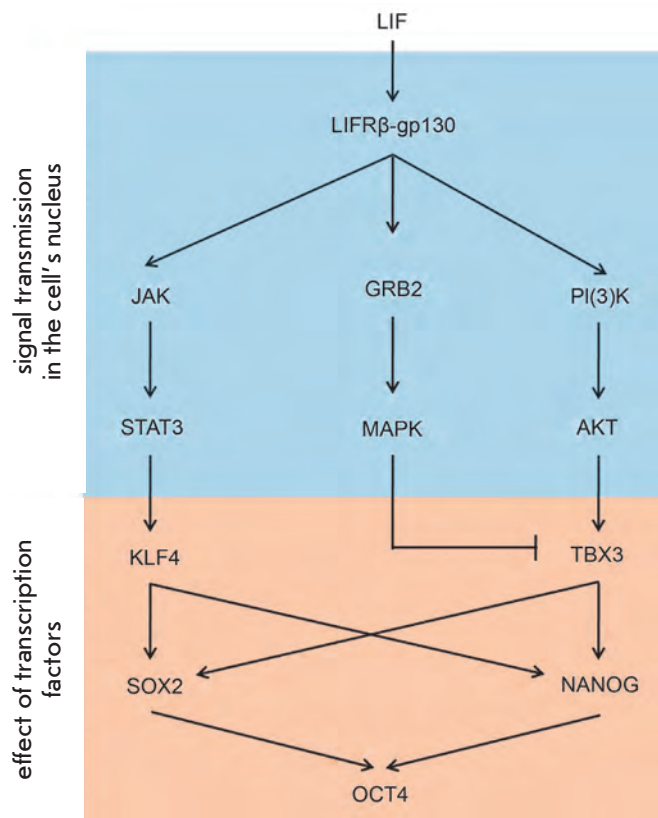

**Fig. 2.** Interplay between transcription factors and LIF-mediated signaling pathways in mouse embryonic stem cells [24].

family members: SMAD6 selectively inhibiting the SMAD1/5 and SMAD7 suppressing protein activators in both branches of the TGFβ superfamily [31].

The TGFβ/ACTIVIN/NODAL signaling pathway plays an essential role in sustaining human ESC (hESC) pluripotency. The ACTIVIN and NODAL proteins act via the same receptors to suppress hESC differentiation [32–34]. Human ESCs express both the ACVR1B and ACVR1B receptors and the TDGF1 (CRYPTO) coreceptor of NODAL, as well as NODAL itself [35]. In hESC cultures, NODAL and ACTIVIN can act in concert with other protein factors, such as bFGF (FGF2) and WNT, in the maintenance of hESC self-renewal [32, 34, 36, 37]. ACTIVIN can activate the production of bFGF, which is necessary for sustaining the self-renewal of hESC cells cultured in the absence of a serum [36]. Both ACTIVIN and NODAL can be replaced with TGFβ in hESC cultures.

The protein factor NODAL plays many different roles during the early embryogenesis of mice. It is necessary for the normal development of embryo epiblast and the maintenance of human OCT4 and NANOG gene expression. A high level of activity of NODAL/

ACTIVIN/TGF $\beta$  directed toward the activation of SMAD2/3B transcription factors (Fig. 1) is observed in undifferentiated hESCs. The transcription factors SMAD2 and SMAD3 are implicated in *NANOG* transcription activation. Undifferentiated hESCs exhibit a high level of phosphorylated (active) forms of SMAD2 and SMAD3. Inhibition of SMAD2/3 phosphorylation by specific inhibitors results in a lowered *OCT4* and *NANOG* gene expression level [32]. During differentiation, the activity of SMAD2 and SMAD3 decreases with an increase in the level of SMAD1/5/8 activating BMP (Fig. 1). SMAD1/5/8 proteins suppress *NANOG* gene transcription. Moreover, SMAD2 and SMAD3, as well as the signaling pathway triggered by FGF2 (bFGF), inhibit the expression of BMP4, thus blocking the spontaneous differentiation of hESCs [37].

The GDF protein, a member of the TGF $\beta$  superfamily, not only inhibits BMP, but also potentiates the effect of NODAL (Fig. 1). The *GDF* gene is expressed in pluripotent cells of humans and mice, through implication in the suppression of the BMP-mediated differentiation. Eventually, GDF influences ESC self-renewal by establishing a balance between SMAD2/3 and SMAD1/5/8 [38, 39] (Fig. 1).

The protein factors of the BMP group have the opposite effect on the self-renewal of murine ESCs (mESCs). BMP4 suppresses neural differentiation and, taken in combination with LIF, sustains the symmetrical self-renewal of mESCs in the absence of both the feeder layer and serum. Murine BMP4 activates the expression of the transcription factor SMAD4 that, in turn, activates the transcription of genes belonging to the *Id* (inhibitor of differentiation) family. It is likely that the expression of the *Id1*, *Id2*, and *Id3* genes in ESCs suppresses the effects of the early expression of genes encoding proneuronal transcription factors (bHLH), particularly *Mash* members, thus preventing differentiation [40]. However, BMP4 in the absence of LIF can have an opposite activating effect on SMAD family factors (SMAD1/5/8), which inhibit the expression of *Id* family genes [40].

Thus, the signaling pathways and cascades triggered by BMP and LIF-JAK-STAT3 have opposite effects on hESC and mESC self-renewal. This is not a solitary example of the species-specific effect of signal molecules. For instance, bFGF is critical in sustaining the undifferentiated state of hESC, but it causes the differentiation of mESCs [41, 42]. Human ESCs express both the receptor and bFGF itself [43, 44]. The effect of bFGF is mediated by tyrosine kinase receptors (ERK1 and ERK2), and inhibition of this signaling pathway results in hESC differentiation (Fig. 1). It is worth noting, however, that the mechanism of bFGF action on hESCs has yet to be understood in detail.

## WNT SIGNALING PATHWAY

Recent studies show that the signaling pathway, of which WNT is a key element, is involved in the short-term maintenance of the pluripotent state of both mESCs and hESCs [45]. The inhibition of glycogen synthase kinase 3 (GSK-3) results in the activation of the WNT signaling pathway and leads to the accumulation of  $\beta$ -catenin in the cells' nuclei and the activation of a series of target genes. However, the expression of the *Oct4*, *Rex1*, and *Nanog* genes, which is specific to pluripotent cells, is retained even in the absence of LIF [46] (Fig. 1). Nevertheless, it was shown later that retaining hESC self-renewal for longer requires TGF $\beta$  and bFGF, and that the action of WNT is restricted to intensifying proliferation [47, 48].

## TRANSCRIPTION FACTORS OCT4, NANOG, AND SOX2

The transcription factors OCT4, NANOG, and SOX2 play a central role in the subsystem of internal regulators of pluripotency. Unlike a system of species-specific signaling pathways, the functions of these transcription factors essentially intersect in sustaining the pluripotency of hESCs and mESCs. Both the genomic organization of the *Oct4*, *Sox2*, and *Nanog* genes and the domain structure of the OCT4, NANOG, and SOX2 proteins are conserved, and the spectra of the target genes of these factors are similar in mESCs and hESCs. Both in mice and humans, OCT4, NANOG, and SOX2 act collectively to form an integrated system regulating gene transcription, including the autoregulation of their own genes.

## TRANSCRIPTION FACTOR OCT4

The OCT4 protein is a POU (Pit, Oct, Unc) class V family of transcription factors. The POU-domain is a bipartite domain composed of two subunits separated by a nonconserved region whose length varies. The N-terminal subunit (75 aa) is known as the POU-specific (POUs) domain, while the C-terminal subunit (60 aa) is a homeobox domain [49–51]. OCT4 expression is characteristic of early embryogenesis in humans, mice, and other mammals [52–56]. In mice, its expression is traced above the two-cell stage and is restricted to the pluripotent cells of ICM and epiblast. In postimplantation embryos, OCT4 is only expressed in germ cells. In human blastocyst, OCT4 is found not only in ICM, but also in the trophoblast [57]. The role of OCT4 in embryogenesis was demonstrated in experiments with *Oct4* knockout mice (the gene *Oct4* is also known as *Pou5f1*, *Oct3*, *Oct3/4*, *OTF3*, and *OTF4*). Homozygous (*Oct4*<sup>-/-</sup>) mouse embryos died at the stage of implantation due to their inability to form ICM (composed of pluripotent cells), while the development of trophoblast was normal [53]. Later, Niwa and colleagues demonstrated the effect of

the *Oct4* expression level on mESC self-renewal [58]. A variation in the *Oct4* transcription level by 50% results in the differentiation of mESCs into either trophoblastic or endodermal derivatives [58]. Moreover, OCT4 activity is necessary for the normal life of murine germ cells [59]. Inhibition of *Oct4* gene expression in murine and human ESCs by means of RNA-interference also results in their differentiation into different derivatives expressing trophoblastic and endodermal markers, such as *Cdx2*, *Gata6*, and *AFP* [60, 61]. Studies of the *Oct4* genomic structure, the structure of the regulatory region, and chromosomal localization in humans and other mammals have shown a highly conserved molecular organization of this gene. Besides, it was shown that in a series of mammal species the *Oct4* gene maps onto a similar syntenic group [62–65]. In mice and other animals, *Oct4* is composed of five exons and localized in the main histocompatibility complex (MHC) region [62, 63, 65, 66]. The human *OCT4* gene is also localized within the MHC region; however, three variants of its alternative splicing, *OCT4A*, *OCT4B*, and *OCT4B1*, were demonstrated [62, 67]. The proteins encoded by these isoforms are involved to different levels in the maintenance of pluripotency. OCT4B, which is largely localized in the cytoplasm, cannot sustain the pluripotency of ESCs [68]. In humans, OCT4A is expressed at the stage of compact morula and blastocyst, whereas OCT4B is expressed in all embryonic cells above the four-cell stage. Moreover, OCT4B is not expressed in hESCs [69]. Unlike the *Oct4* of other animals, human *OCT4* has four exons. The second exon is subdivided into four subexons (2a, 2b, 2c, and 2d) that differently combine with each other in three different variants of transcript splicing. The variant *OCT4A* is composed of exons 1, 2b, 2d, 3, and 4; *OCT4B* – 2a, 2b, 2d, 3, and 4; *OCT4B1* – 2a, 2b, 2c, 3, and 4. Thus, the human *OCT4* gene transcripts are identical in 3'-area (exons 3 and 4), and the difference only concerns exons 1 and 2. The *OCT4A* transcript encodes a protein with a length of 360 aa. The size of OCT4B is 265 aa; however, in some parts of the population this protein type is not translated because of the polymorphism of its start codon (AU/GG) [62, 70]. Another two isoforms, OCT4B-190 and OCT4B-164 composed of 190 and 164 aminoacid residues, respectively, can be translated from the recently found alternative ribosome-binding site localized in the area of the *OCT4B* transcript subexons 2a-b. The protein product of *OCT4B1* was not found, maybe because of the *UGA* stop codon in the subexon 2c that is absent in *OCT4B* [67]. It was shown earlier that the protein encoded by the *OCT4A* isoform is localized in the cell nucleus and involved in the regulation of gene transcription, while the OCT4B protein is localized in the cytoplasm and cannot maintain pluripotency [57,

68]. Later, it was found that both *OCT4B* products, OCT4B-190 and OCT4B-164, are dispersed in both the nucleus and cytoplasm [70]. In hESCs, the level of OCT4B-190 considerably increases in response to stress conditions and can inhibit apoptosis. No expression of OCT4B-265 and OCT4B-164 was found in hESCs [70].

### TRANSCRIPTION FACTOR NANOG

The transcription factor NANOG is a homeodomain protein that shares a very high degree of homology and structural resemblance with NK family proteins [71]. The expression of the *NANOG* gene is characteristic of preimplantation embryo pluripotent cells (ICM and epiblast), as well as murine and human ESCs [72–74]. *Nanog* overexpression can lead to the retention of mESC pluripotency, even in the absence of interleukin LIF [72]. The mutation analysis of *Nanog* has shown how necessary this gene expression is for normal embryonic epiblast development and maintenance of mESC self-renewal. ESCs with the genotype *Nanog*<sup>-/-</sup> differentiate into extraembryonic derivatives [73]. Suppression of *NANOG* expression in hESCs results in differentiation accompanied by elevated expression of endodermal (*GATA4*, *GATA6*, *LAMININ B1*, and *AFP*) and trophodermal (*CDX2*, *GATA2*, *hCG- $\alpha$* , and *hCG- $\beta$* ) markers.

The murine *NANOG* molecule in mice has several functional elements involved in transactivation. These include the homeodomain, which occupies a central position in the protein, and three C-terminal elements: CD1 (C-terminal domain 1), CD2, and the tryptophan repeat (W-repeat) localized between CD1 and CD2. Homeodomain, CD2, and the W-repeat chiefly contribute to the transactivation of murine *NANOG* [75, 76]. Recent studies have shown that the murine *NANOG* W-repeat provides transactivation; it is involved in *NANOG* protein dimerization that is necessary for LIF-independent maintenance of mESC pluripotency [77, 78]. In all likelihood, tryptophan residues are the most essential. Their replacement by alanines results in a substantial decrease in the murine *NANOG* transactivation capability, whereas the replacement of any other aminoacid residue in the W-repeat monomer has no significant effect on this activity [76]. Another important transactivation element of *NANOG* is CD2 [79]. This element is required for the *NANOG*-mediated self-renewal of mESCs. CD2 domain activity depends on aromatic residues (phenylalanine and tyrosine). Replacement of these aminoacids leads to a decrease in the CD2 and entire *NANOG* activity and, as a result, leads to ESC differentiation [79]. Nevertheless, a comparison of different mammalian CD2 sequences has shown that the majority of aromatic aminoacid residues are not conserved to a high level [80].

### TRANSCRIPTION FACTOR SOX2

Transcription factor SOX2 (SRY-related HMG box) contains the DNA-binding HMG (high mobility group)-domain. Expression of SOX2, as well as OCT4, is characteristic of the ICM, epiblast, and germ cells of mice embryos [81].

Homozygous SOX2 mutant embryos die at the stage of implantation because of the epiblast hypoplasia. It is impossible to obtain stable ESC lines from mutant embryos, but both TSC and extraembryonic endodermal lines are easily prepared [81]. In addition, a normal expression of *Sox2* gene is necessary for sustaining the self-renewal of murine and human ESCs [82, 83]. Both suppression and overexpression of SOX2 cause trophodermal differentiation of hESCs [83].

### GENE TARGETS FOR OCT4, NANOG, AND SOX2 TRANSCRIPTION FACTORS

OCT4, NANOG, and SOX2 are the proteins whose expression is necessary for sustaining murine and human ESC pluripotency under standard culturing conditions. It is evident that their function as transcription factors determines general ESC features. At present, much data exist concerning the spectrum of target genes for these proteins.

The transcription factor OCT4 can serve as the activator and repressor of many target genes, such as *Fgf4*, *Opn*, *Utf1*, and the genes encoding human chorionic gonadotropin  $\alpha$ - and  $\beta$ -subunits, most of them participating, in one way or another, in early embryo development [84–88]. The regulatory forms of OCT4 are mono-, homo-, and heterodimer, depending on the target gene [89]. For instance, the OCT4 homodimer regulates the transcription of *Opn*. The enhancer element of *Opn* contains a palindromic sequence called PORE (palindromic-oct-regulatory-element), which contains the octameric ATGCAAAT motif (octameric site for the docking of the OCT monomer) and the ATTTG sequence separated from the octameric motif by two nucleotides. The SOX2 docking site is localized near PORE; however, it exerts a suppressing effect on *Opn* transcription [84].

The OCT4 and SOX2 factors can act in conjunction. They positively regulate *Fgf4* and *Utf1* genes, and their docking sites are localized in the enhancers localized in the 3'-nontranslated regions of these genes [85, 86, 90]. Aside from PORE, another element exists which interacts with OCT monomers and dimers; it was named MORE (more of PORE, ATGCATATGCAT) [91, 92]. MORE and PORE elements are substantially different in the relative localization of the POU-specific domain and POU-homeodomain. Despite an initially artificial synthesis of MORE, similar elements were found in the regulatory regions of natural genes [91–93]. OCT1 and

OCT4 transcription factors can influence the target gene's transcription via MORE elements in response to genotoxic and oxidative stresses [93].

The development of high-performance methods for the distribution analysis of transcription factors at the whole genome level has substantially broadened our knowledge of the spectrum of OCT4, NANOG, and SOX2 target genes. Two research groups have localized OCT4, NANOG, and SOX2 in the human and mouse ESC genomes using ChIP-on-Chip and ChIP-PET (chromatin immunoprecipitation – paired-end ditag) methods [22, 23].

The distribution of binding sites for the OCT4, NANOG, and SOX2 transcription factors in human H9 ESCs was analyzed by Boyer and colleagues [22]. The genes encoding transcription factors and the components of signaling pathways which, as determined earlier, are implicated in early embryogenesis, cell differentiation, organogenesis, and maintenance of ESC's self-renewal and pluripotency in culture are a major part among the genes associated with these transcription factors. Particularly, they are OCT4, SOX2, NANOG, LEFTY2/EBAF, CDX2, HAND1, DPPA4, GJA1/CONNEXIN43, FOXO1A, CRIPTO/TDGF1, and ZIC3 [94–102]. Then, the distribution of binding sites for the NANOG and SOX2 factors was determined in the same way. The OCT4, SOX2, and NANOG transcription factors jointly regulate 353 genes in hESCs; they can act as transcription activators or repressors [22]. The transcription factor genes, such as OCT4, NANOG, and SOX2, as well as genes encoding components of the signaling pathways implicated in the sustenance of self-renewal, such as TGF $\beta$  (TDGF1, LEFTY2/EBAF) and WNT (DKK1, FRAT2), make up a large portion of the genes positively regulated by OCT4, NANOG, and SOX2 [22]. Also, transcription factor genes, such as *Rcor2*, *Esrrb*, and *Phc1*, were revealed in mESCs among the genes positively regulated by the OCT4 and NANOG factors [23]. In addition, *Pou5f1* (encoding the OCT4 transcription factor) and *Sox2* are on the list of the genes positively regulated by NANOG in mESCs. Early experimental data also suggest the involvement of the OCT4 and SOX2 factors in the regulation of the *Pou5f1*, *Sox2*, and *Nanog* genes [97, 99, 100, 103]. It appears that autoregulation is the general property of the system maintaining pluripotency in mice and humans. The abundance of genes encoding transcription factors (such as REST, SKIL, HESX1, and STAT3) among the positively regulated genes suggests that OCT4, NANOG, and SOX2 are only the tip of an iceberg, hiding a far more complex system of transcription regulation in ESCs. Many genes encoding the transcription factors (for instance, ESX1I, HOXB1, MEIS1, PAX6, LHX5, LBX1, MYF5, ONECUT1) involved in differentiation

during embryo development are found among the negatively regulated genes [22]. It is very likely that the OCT4, NANOG, and SOX2 factors participate in the repression of these genes both *in vivo* and *in vitro*.

Data published in two studies seem to indicate that the binding sites for the OCT4, NANOG, and SOX2 transcription factors are associated with the genes encoding miRNAs [22, 23]. In hESCs, the docking sites for OCT4, NANOG, and SOX2 are found in the promoters of 14 miRNA genes; they are all present in the *mir-137* and *mir-301* promoters. In mESCs, the binding sites for NANOG are localized within a distance of 6 kbp from four miRNA genes: *mir-296*, *mir-302*, *mir-124a*, and *mir-9-2*. Moreover, no other genes are found in close vicinity to the NANOG site in the case of the *mir-296*, *mir-124a*, and *mir-9-2* genes. The docking site for NANOG is found within a 30-kbp region for the *mir-135* gene, while OCT4 binds in close vicinity to the NANOG site near the *mir-296* and *mir-302* genes.

A comparison of data on the revelation of target genes for the OCT4 and NANOG transcription factors in mouse and human ESCs demonstrates that only a minor portion of these genes are simultaneously found in the genomes of both species. So, only 9.1% OCT4-associated genes and 13% NANOG-associated genes overlap in these two species. This may be evidence of an essential difference in the composition of the gene nets controlled by OCT4 and NANOG. However, a group of 32 genes is regulated by OCT4 and NANOG in both mouse and human, 18 of them encoding transcription factors, including OCT4, SOX2, and NANOG, suggesting the importance of these genes in sustaining pluripotency [23]. The difference in the compositions of the target genes found in these two studies may have a technical origin, because two different methods were employed in the works (ChIP-on-Chip and ChIP-PET, respectively) to obtain data and process them.

Thus, the OCT4, NANOG, and SOX2 transcription factors are in the center of a broad regulatory net including transcription factors (whose genes are positively or negatively regulated), components of signaling pathways, and miRNAs. The stable functioning of this net is evidently necessary for sustaining self-renewal and pluripotency in both human and murine ESCs.

### PROTEIN-PROTEIN INTERACTIONS IN THE PLURIPOTENCY MAINTENANCE SYSTEM IN EMBRYONIC STEM CELLS

Recent studies provide much evidence pointing to the fact that the transcription factors involved in the maintenance of ESC self-renewal not only exert joint control on target gene transcription, but they are also in physical contact with each other [104–108]. For instance, NANOG can suppress BMP-initiated mesodermal differentiation in mESCs via binding with SMAD1 and

physically interact with the SALL4 transcription factor to execute joint positive regulation of the *Nanog* and *Sall4* gene enhancers [104, 106]. However, these were only particular examples of protein-protein interactions of NANOG directed toward the maintenance of ESC self-renewal. A wider analysis of NANOG interactions on mESCs has demonstrated a broad spectrum of interactions. The set of interacting proteins includes not only transcription factors, but also the proteins implicated in chromatin structure regulation [105]. Wang and colleagues [105] applied a method based on the expression of the NANOG protein containing FLAG-epitope and a short amino acid sequence serving as the substrate for BirA, the *Escherichia coli* biotin ligase. A NANOG containing two additional epitopes was expressed (at the level of about 20% of the endogenous level) in mESCs that also expressed BirA, and the cells retained self-renewal and pluripotency. NANOG complexes were isolated from the nuclei extract either by using streptavidin-agarose or by immunoprecipitation with antibodies against FLAG, followed by purification on streptavidin-agarose. The proteins interacting with NANOG were identified using mass-spectrometry (whole-lane liquid chromatography–tandem mass spectrometry, LC–MS/MS).

Several regularities can be detected from the data obtained in this experiment. In the first, the group of proteins interacting with NANOG is much enriched in the factors required for the normal viability and differentiation of ICM cells (pluripotent embryo compartment) in mouse blastocyst. Besides, according to data in the literature, more than 80% of NANOG-interacting proteins, such as OCT4, DAX1, NAC1, ZFP281, and SALL4, are required for the acquisition and maintenance of general ESC properties [105].

Secondly, most of the revealed proteins possess a similar expression pattern, which is typical of pluripotent cells, and their expression is suppressed under ESC differentiation, likely suggesting their involvement in similar processes or in the same regulatory system [105].

Thirdly, in human and murine ESCs a large portion of genes encoding the proteins interacting with NANOG represents putative targets for OCT4 and NANOG [22, 23, 63]. The system sustaining ESC self-renewal and pluripotency in mice and humans undergoes autoregulation with positive and negative feedbacks, a feature that is necessary for both the stability of the undifferentiated state and the realization of a strict differentiation program in a distinct direction [97, 99, 100, 103]. It is likely that the maintenance of pluripotency or direction of cell differentiation depends on the stoichiometric ratio between the molecules of different factors. This hypothesis is supported by experimental data on



ESC multidirectional differentiation depending on the transcription levels of the *Oct4*, *Nanog*, and *Sox2* genes [58, 83, 109].

Fourthly, NANOG can interact via its partners with multiple proteins involved in the epigenetic regulation of gene expression. NANOG – via interaction with OCT4, DAX1, NAC1, ZFP281, or SALL1/4 – can form complexes with components of the NuRD complex (P66B and HDAC2) possessing histone acetylase activity, Polycomb proteins (YY1, RNF2, and RYBP), and components of the SWI/SNF (BAF155) chromatin remodeling complex [105]. The interaction of NAC1 and SALL1 with histone deacetylases has been experimentally proved [110, 111].

Complexes formed by NANOG and other proteins are apparently functional, rather than occasional short-live intermediates observed in a single experiment. For instance, the complex formed by NAC1, ZFP281, and NANOG interacts with the *Gata6* promoter (the marker of endodermal differentiation) to inhibit it.

Interaction between OCT4 and other protein molecules was also reported in a series of works [85, 112–114]. Particularly, these are interactions between OCT4 and transcription factors with the formation of heterodimers that are necessary for regulating target gene transcription. In addition, proteins interacting with OCT4 and inhibiting this factor were found using the yeast two-hybrid system and co-immune precipitation [115]. SUMO-ligase PIASy, as well as PIAS1, and PIAS3 proteins belonging to the same family interact with OCT4. Despite PIASy being a known SUMO-ligase and the OCT4 protein containing sumoylation sites, the inhibitory effect of the ligase was experimentally proved to be independent of this activity. PIASy exerts the inhibitory effect on the transactivating capability of OCT4, acting as a monomer, homo-, or heterodimer, whereas PIAS1 and PIAS3 do not exhibit this action. Also, the PIASy, PIAS1, and PIAS3 proteins induce the relocation of OCT4, pushing it to the nucleus's periphery [115].

Two research groups recently carried out a study on the patterns of protein–protein interactions of the OCT4 factor, as well as its known partners: SALL4, TCF2L1, DAX1, and ESRRB in mESCs [107, 108]. The authors employed an approach based on the expression of a chimeric protein (OCT4 in this case) containing known epitopes, which are necessary for the isolation of its complexes with other proteins from cellular or nuclear extracts. Expression of *Oct4* under its natural promoter was used in one of these works [107]. Like in the work by Wang and colleagues [105], components of the NuRD, SWI/SNF, and PRC1 complexes involved in the regulation of the chromatin structure were found among the proteins interacting with

OCT4 [107, 108]. Also, some enzymes participating in the epigenetic regulation of gene expression, such as MYST2 (histone acetyltransferase H4), DNMT3A (*de novo* DNA-methyltransferase), and some other proteins, were found in OCT4 complexes. Some proteins involved in the posttranslational modification of OCT4 itself, particularly OTG (enzyme attaching O-bound N-acetyl glucosamine), modifying OCT4 in hESCs were also found [107, 108, 116]. The transcription factors necessary for the maintenance of ESC self-renewal, such as KLF4, SOX2, SALL4, and ZFP281, are found among the partners of OCT4. Analysis of the functions of OCT4 partners using information from databases has shown that they are mostly involved in early development and cell differentiation and that their knockout induces death during the early development of the embryo [107]. All genes determined as OCT4 partners in mESCs have human homologues. Moreover, the amino acid sequences of the proteins encoded by these genes show a very high, more than 94%, homology between mice and humans (the average level is 77%). These genes are closely associated with the development of inherited diseases in humans (mostly with developmental disorders) and cancer [107].

Thus, gene regulation directed toward the maintenance of self-renewal and pluripotency appears more complex than was earlier thought. Not just the suppression or activation of target genes by distinct protein molecules of the transcription factors is involved in the regulation. There are molecular complexes implicated in the regulation which contain not only transcription factors, but also proteins remodeling the chromatin structure. The quantitative ratio of the molecules in each separate cell can directly or indirectly influence its self-renewal and direction of differentiation.

#### EPIGENETIC REGULATION OF CELL PLURIPOTENCY

ESCs possess a virtually unlimited potential for self-renewal and differentiation into a very broad spectrum of cell types. Global changes in morphology, physiology, division rate, and other parameters occur during cell differentiation. These changes are caused and accompanied by a global change in the gene expression pattern. Currently, gene expression is known as a process that is strictly regulated at the epigenetic level. Epigenetic regulation includes covalent modification of histones (nucleosome-forming proteins) and DNA methylation in gene promoter regions. Numerous types of histone modifications, such as acetylation, methylation, phosphorylation, ubiquitylation, etc., are known, consisting in the attachment of chemical groups and regulatory peptides (ubiquitin, SUMO) to the amino acid residues of histones. Histone modifications alter the physical properties of nucleosomes, thus making chro-

matin more or less accessible to the factors providing gene transcription. The modifications associated with active chromatin and actively transcribed genes and, alternatively, the modifications associated with inactive chromatin and often associated with transcription suppression have been distinguished. In particular, the acetylated forms of the histones H3 and H4 and histone H3 trimethylated at position K4 (H3K4me3) (K is lysine, according to the single-letter nomenclature) are “active” modifications. Alternatively, histone H3 di- and trimethylation at position K9 (H3K9me2 and H3K9me3) and histone H3 di- and trimethylation at position K27 (H3K27me2 and H3K27me3) are “inactive” chromatin modifications. Moreover, inactive chromatin is characterized by histone deacetylation.

In mammals, DNA methylation touches cytosines within the CpG-dinucleotide islets. These islets are often observed in promotor regions, and their hypermethylation is commonly associated with transcription suppression.

Studies on the localization of modified histones in the genomes of embryonic stem cells demonstrate that the distribution of active and inactive modifications is rather unusual and specific to pluripotent cells. The presence of bivalent domains simultaneously containing the labels of active and inactive chromatin (H3K4me3 and H3K27me3) was discovered in the mESC genome [117]. A distribution analysis of histone H3 active and inactive modifications has been carried out for 56 regions enriched with highly conserved noncoding element (HCNE) sequences. HCNE-enriched regions generally not contain many genes: however, they do encompass a relatively large number of genes encoding the transcriptional factors implicated in the regulation of development. For instance, all four clusters of the HOX gene family are localized in these regions. Within HCNE, Bernstein and colleagues [117] have demonstrated the presence of 343 H3K4me3-enriched regions averaging 3.4 kb; 63% of them are co-localized with the transcription initiation points of known genes. In addition to this, 192 regions enriched with H3K27me3 were found within HCNE sequences with a maximum length of 18 kb in the gene clusters of the HOX family. A comparison of data on the H3K4me3 and H3K27me3 distributions has revealed domains containing both modifications. Nine similar domains were found in HOX clusters; 95, in other HCNE-enriched regions; whereas only five bivalent domains were identified in control loci [117].

Most bivalent domains in HCNE-enriched regions are associated with the transcription initiation points of the genes encoding transcription factors. These genes are members of the SOX, FOX, PAX, IRX, and POU families, whose distinct members play important roles in cell differentiation during development. However, 26

bivalent domains were found beyond the transcription initiation points; they are also associated with the genes implicated in development. For instance, bivalent domains are found in the 3'-regions of the *Npas3*, *Meis2*, *Pax2*, and *Wnt8b* genes. Bivalent domains are present in the *Fgf8* and *Prok1* genes that do not encode transcription factors but participate in the development of the nervous system [117].

An extremely small number of bivalent domains were found in the differentiated cells studied by the authors, such as embryonic fibroblasts, primary lung fibroblasts, C2C12 myoblasts and Neuro2a neuroblastoma cells. At the same time, extended regions enriched separately with H3K4me3 or H3K27me3 were found. In differentiated cells, the overwhelming majority of the domains among the bivalent ones revealed in mESCs contained extended regions represented by only one modification, depending on cell type [117].

The genes, whose transcription start points are associated with bivalent domains, are characterized by a low transcription level, despite the presence of H3K4me3, the active chromatin label, thus suggesting a “predomination” of H3K27me3 over H3K4me3. The authors studied the distribution of the modifications in the bivalent domains associated with gene transcription start points during a directed ESC differentiation into neural cell progenitors. The genes with a high transcription level after the differentiation lost the H3K27me3 modification, while the genes transcribed at a low level enhanced enrichment in H3K4me3, in line with the preservation of H3K27me3, and nontranscribed genes preserved H3K27me3 and lost H3K4me3 [117].

Thus, a specific system of epigenetic gene regulation exists in the ESCs involved in cell differentiation. Apparently, it enables pluripotent cells to keep distinct genes in the “low start” state and rapidly start their transcription depending on differentiation programs and type of the formed differentiated cells.

The molecular mechanisms underlying the epigenetic regulation of gene expression in ESCs are being studied in detail. Polycomb group proteins are one of the main actors in the epigenetic regulatory system in embryo development in organisms and ESCs [118]. Numerous biochemical and genetic studies show that Polycomb proteins form two independent complexes: PRC1 (Polycomb repressive complex 1) and PRC2. The main components of these complexes are highly evolutionarily conserved and necessary for a normal embryonic development of various organisms, from drosophila to mouse and humans [118–122].

Boyer and colleagues have analyzed the localization of the main components of PRC1 (PHC1, RNF2) and PRC2 (SUZ12, EED) complexes in the regions flank-

ing the transcription start points (from -8 to +1 kb) of about 16,000 genes in mESCs [123]. The authors have found that PRC1 and PRC2 proteins are mostly localized within 1 kb of the transcription start point of 512 genes, thus suggesting their involvement in the regulation of these genes. Earlier, PRC2 was shown to be responsible for the establishment of H3K27me<sub>3</sub>, the label of inactive chromatin. The study has demonstrated that H3K27me<sub>3</sub> enrichment takes place in all 512 genes whose 5'-regions can carry PRC1 and PRC2 proteins. The genes encoding homeodomain-containing transcription factors represent a significant portion of them. Previously known targets of Polycomb proteins – factors of the HOX family and other transcription factors belonging to DLX, IRX, LHX, POU, PAX and SIX families – belong to this group. A common feature of the factors belonging to these families is their implication in cell differentiation and regulation in embryo development and organogenesis. Genes whose products are implicated in the regulation of development despite the absence of a homeodomain were also revealed. These are proteins of FOX, SOX, GATA, and TBX families. In cells bearing homozygous EED mutation (one of the PRC2 components), a high expression level of genes belonging to various families is observed, although these genes are silenced in normal ESCs [123].

Thus, multiple genes implicated in differentiation and embryo development in mESCs are targets for PRC. Hence, PRC1 and PRC2 can play a substantial role in the maintenance of ESC self-renewal and pluripotency.

Similar results were obtained in a study on the localization of the SUZ12 protein (another PRC2 component) in hESCs [124]. The authors also succeeded in proving that PRC2 components are localized in the vicinity of the transcription start points of the genes implicated in many processes associated with cell differentiation during embryo development. Besides, in hESCs the SUZ12 protein is localized in the promoters of genes encoding the protein components of the signaling pathways involved in gastrulation, differentiation during ontogenesis, as well as in the self-renewal and differentiation of ESCs in culture. Among these genes, there are components of signaling pathways triggered by TGFβ, BMP, WNT, and FGF. SUZ12 is localized in distinct promotor regions, as well as in extended sites encompassing several genes belonging to one signaling pathway, such as WNT (WNT1, WNT2, WNT6) and TGFβ (BMP2, GDF6). Earlier, these signaling pathways were proven to participate in the regulation of self-renewal and pluripotency in murine and human ESCs [46]. Hence, PRC2 can directly influence ESC properties by regulating the components of these signaling pathways. However, the later data suggest maintenance of pluripotency in mESCs bearing the mutant EED [125]. ESCs bearing the homozygous EED mutation express

OCT4 and NANOG and form chimeras. Although this work was a failure in its attempt to obtain adult chimeric mice, a large extent of chimerization was observed in 12.5 day-old embryos. An attempt to obtain a culture of embryonic fibroblast descendants of the mutant ESCs failed, likely due to the low viability of differentiated mutant cells. Chimeric embryos (with a high percentage of chimerization) also had several defects, such as hypertrophy of allantois and underdeveloped neuroectoderm and embryonic mesoderm, which possibly caused embryo death at the stage of about 10.5 days after fertilization [125].

A high frequency of SUZ12 co-localization with the already-mentioned HCNE (bivalent chromatin domains are localized in HCNE-enriched regions) is an interesting regularity described by Lee and colleagues [124]. Approximately 8% of the 14,000 HCNEs discovered earlier [126] are enriched in SUZ12, and the more evolutionary conserved the element, the higher the level of enrichment [124].

Besides, one-third of the genes regulating development and binding to PRC2 are also under the control of at least one of the three transcription factors, OCT4, SOX2, or NANOG, which are the key factors in the system of murine and human ESC pluripotency maintenance [22, 124]. These genes (such as *ESX1L*, *ONECUT1*, *HAND1*, and *HOXB1*) are involved in the development of extraembryonic tissues, as well as the ecto-, meso-, and endoderm. The transcription factors comprising the system of pluripotency maintenance can directly regulate the genes encoding PRC2 components. So, the transcription factors OCT4 and STAT3 (the activity of the latter depends on the presence of interleukin LIF) are positive regulators of the *Eed* gene in mESCs [127]. At the same time, OCT4 is a negative regulator of the *Hdac4* gene encoding histone deacetylase in mESCs [128]. These factors are examples of collaboration between the system of epigenetic regulation of gene expression and the system of ESC pluripotency maintenance.

The genes implicated in the maintenance of ESC pluripotency and self-renewal are subjected to epigenetic alterations during differentiation in embryogenesis and during induced or spontaneous differentiation *in vitro*. The *Oct4* gene slightly differs from other genes (*Dppa3/Stella/PGC7*, *Nanog*, and *Sox2*) with expression typical of pluripotent cells in its mechanism of epigenetic silencing during differentiation [129]. The labels of inactive chromatin, namely H4K9 methylation, and the presence of the HP1 heterochromatin protein are typical of the *Oct4* promotor region in differentiated cells of P19 embryonic carcinoma and post-implantation murine embryos. The same type of epigenetic silencing is observed in the *Rex1* gene, whose transcription is positively regulated by OCT4 (this mechanism was not observed

in the *Nanog* and *Sox2* genes). The presence of H3K9me and HP1 favors the *de novo* recruiting of DNMT3A and DNMT3B, two DNA-methyltransferases methylating the promoter region of the *Oct4* gene, which is necessary for complete and stable transcription suppression. DNA methylation is the secondary process in relation to H3K9 methylation; a fact proven when studying the differentiation of mESCs bearing homozygous mutations of the gene encoding G9a histone methyltransferase and the genes *Dnmt3a* and *Dnmt3b* encoding DNA-methyltransferases. It was also shown recently that mutations interfering with H3K9 and DNA methylation inhibit ESC differentiation [129].

The necessary presence of euchromatin proteins in the sustenance of mESC pluripotency was established recently [130]. Repression of *Chd1* gene transcription suppresses both ESC cell culture growth and *Oct4* gene promoter activity. This gene encodes the euchromatin protein, which is co-localized with the H3K4me3 label of active chromatin and RNA-polymerase II in mESCs. Suppression of *Chd1* transcription results in elevated expression of neural markers in ESCs and impairment of cell differentiation into primitive endoderm and, as a consequence, into cardiac mesoderm descendants. At that stage, the ectodermal type of differentiation occurs normally. Besides, *Chd1* suppression drastically reduces the efficacy of iPSC production from embryonic fibroblasts [130]. Note that the transcription factors, such as OCT4, SOX2, NANOG, SMAD1, ZFX, and E2F1, required for the maintenance of cell pluripotency are localized within the *Chd1* gene in ESCs [131].

The link between pluripotency and epigenetic mechanisms can be tracked in experiments on murine and human iPSC production. Several studies have demonstrated that specific inhibitors of the enzymes implicated in the epigenetic modification of histones and DNA substantially increase the efficacy of iPSC production and can even substitute some “factors of pluripotency.” Currently, similar properties are known for the inhibitors of histone deacetylases (valproic acid (VPA), trichostatin A (TSA), and suberoylanilide hydroxamic acid (SAHA)) [132, 133], G9a histone methyltransferase inhibitor BIX-01294 [134, 135], and DNA methyltransferase inhibitors 5-azacytidine and RG108 [132–136]. Besides, the use of RNA interference against *Dnmt* increases the efficacy of reprogramming due to the enhancement of partially reprogrammed cell transitions to a completely reprogrammed state [136]. Numerous studies devoted to the production of iPSCs of human and other animals have demonstrated that reprogramming somatic cells to the pluripotent state is accompanied by DNA demethylation in the promoter regions of *Oct4* and *Nanog*, whereas they are hypermethylated in murine somatic cells and TSCs [137, 138].

### miRNAs AND PLURIPOTENCY

Numerous studies indicate that miRNAs play an important role in the regulation of the expression of multiple genes during embryo development. In particular, a mutation in the *Dicer* gene encoding the RNase involved in small noncoding RNA processing cause early death of murine embryos [139]. A similar effect is observed in mutants bearing the *Dgcr8* gene mutation (its protein product comprises the Microprocessor complex, which is also implicated in miRNA biogenesis). ESCs with mutations in the *Dicer* and *Dgcr8* genes are characterized by the disturbance of both the cell cycle and ability to differentiate [140–142].

To date, more than 500 various miRNAs with their expression typical in various tissues and types of differentiated cells are known. The expression of some miRNA families is restricted to undifferentiated ESCs. In murine ESCs, these families are *mir-290* (*mir-290*, *mir-291a*, *mir-291b*, *mir-292*, *mir-293*, *mir-294*, and *mir-295*) and *mir-302* cluster (*mir-302a*, *mir-302b*, *mir-302c*, *mir-302d*, and *mir-367*). In human ESCs, expression of *mir-302* family miRNAs occurs, as well as *mir-371* (*mir-371*, *mir-372*, and *mir-373*), whose representatives are homologous to those of murine *mir-290* [143].

To date, the data in numerous experiments support the notion of a tight interaction between the system of miRNA-mediated regulation of gene expression and the system of transcription factors of pluripotency, including OCT4, NANOG, and SOX2. Transcription factors can regulate the transcription of distinct genes and whole miRNA clusters, whereas miRNAs are capable of regulating *Oct4*, *Nanog*, and *Sox2* expression at the posttranscriptional level [22, 23, 143]. For instance, *mir-134*, *mir-296*, and *mir-470*, whose expression is elevated under induced differentiation of mESCs, can regulate *Oct4*, *Nanog*, and *Sox2* in various combinations, causing a decrease in the levels of the corresponding proteins [144]. An increase in the *mir-134* transcription level can induce mESC differentiation via the ectodermal pathway. The mRNAs of the *Nanog* and *LRH1* genes, whose protein products positively regulate the *Oct4* gene, are the targets of *mir-134* [145]. It was shown later that *mir-200c*, *mir-203*, and *mir-183* miRNAs can co-repress *Sox2* and *Klf4*, which is also required for the maintenance of mESC pluripotency [146]. Induction of this miRNA decreases the capability of self-renewal and leads to the induction of differentiation markers. In hESCs, the miRNA named *mir-145* is also found. Its activation induces differentiation. The OCT4 transcription factor represses the transcription of *mir-145* in nondifferentiated hESCs [147].

Localization of transcription factors in the human and murine ESC genomes has demonstrated that the

genes encoding miRNAs are among the targets of OCT4, SOX2, and NANOG [22, 23].

Highly precise distribution mapping of the transcription factors OCT4, SOX2, NANOG, and TCF3 in mESCs has shown that these transcription factors are co-localized within 55 miRNA loci, including three polycistronic clusters comprising 20% of all annotated mammalian miRNAs [143]. These miRNAs include both those that are actively transcribed in ESCs, as well as silencing forms. Hence, the transcription factors of pluripotency can act as activators and repressors of miRNA transcription in ESCs. Besides, polycomb proteins executing di- and trimethylation of histone H3 at position K27 (the label of inactive chromatin) are found in the promoter regions of the miRNA genes repressed by OCT4, SOX2, NANOG, and TCF3 (Fig. 3). Transcription rearrangement occurs under cell differentiation, resulting in the formation of specific patterns of miRNA expression in each of the differentiated cell types [143].

Apparently, miRNA can be implicated in cell reprogramming as well. It was shown that ESC-specific *mir-291-3p*, *mir-294*, and *mir-295* miRNAs can increase the efficacy of murine iPSC production without the use of *c-Myc* [148]. Besides, human iPSCs have been successfully produced using ectopic expression of the *OCT4*, *SOX2*, *KLF4*, and *LIN28* genes. The protein product of the *LIN28* gene inhibits the production of let-7 family miRNA, which participates in cell differentiation [149].

**TRANSCRIPTION FACTORS OCT4, Sox2, AND NANOG AND X-CHROMOSOME INACTIVATION**

The system that sustains cell pluripotency self-renewal with OCT4, SOX2, and NANOG playing the central role is associated with the fundamental genetic processes that occur in early embryogenesis in mammals, particularly, X-chromosome inactivation.

In females of higher mammals, one of two genetically equivalent X-chromosomes undergoes inactivation, which is heterochromatinization and transcription silencing of most of its genes. The inactivation process consists of several studies and is managed by a complex genetic locus, the inactivation center, localized in the X-chromosome [150]. Imprinted inactivation is observed in all murine embryo blastomers at very early developmental stages; i.e., exclusively the male-derived X-chromosome undergoing inactivation. Reactivation of the inactivated X-chromosome occurs after separation from ICM, a pluripotent compartment of the blastocyst. The imprinted inactivation is retained in extraembryonic tissues, whereas random inactivation of the X-chromosome becomes established in epiblast cells under differentiation. *Xist* and *Tsix*, which are transcribed antisenses to *Xist* from a complementary DNA strand, are two genes of the inactivation center that play a crucial

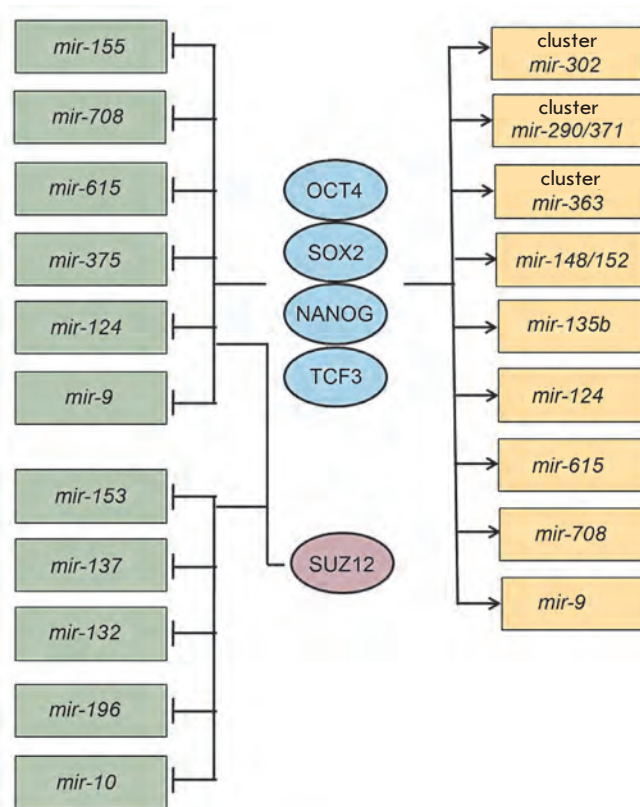
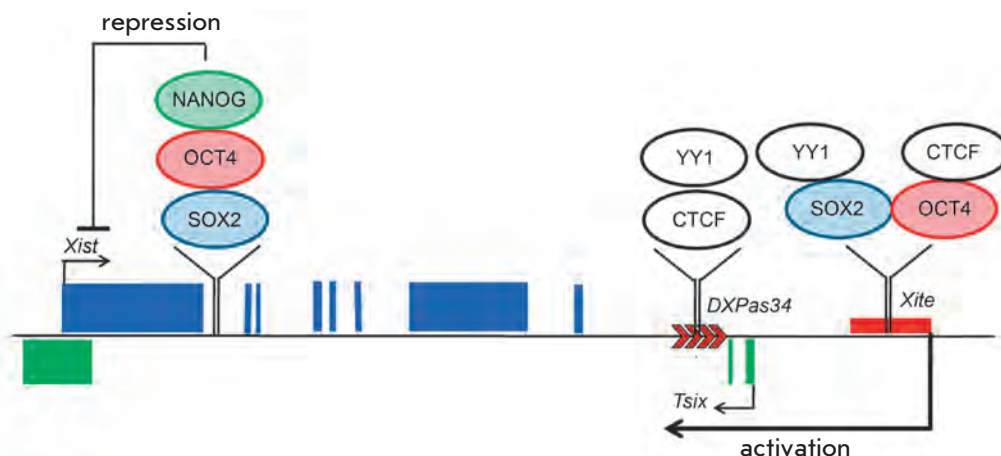

**Fig. 3.** miRNA genes associated with transcription factors OCT4, SOX2, NANOG, and TCF3 (indicated by arrows) and co-regulated by these factors and PRC2 (SUZ12) in murine and human embryonic stem cells [143].

role in X-inactivation [151–153] (Fig. 4). Both genes encode nontranslated nuclear RNAs. The RNA of the *Xist* gene spreads along the X-chromosome, triggering the inactivation. *Tsix* transcription has a suppressing effect on the transcription of the *Xist* gene [152].

Both X-chromosomes are active in both ESCs and ICM cells, in which the level of *Xist* RNA is extremely low [154]. Fluorescence *in situ* hybridization (FISH) allows to visualize the *Xist* transcript as a shining dot on each X-chromosome. Random inactivation of one parent X-chromosome occurs during ESC differentiation, like in embryonic epiblast cells after the implantation into the uterus. Therefore, an obvious correlation between pluripotency and X-chromosome inactivation exists in female mammal cells. The molecular origin of this correlation was not elucidated until recently.

A link was recently found between OCT4, SOX2, and NANOG. It appears to play a key role in the maintenance of ESC pluripotency and X-chromosome inactivation [155]. OCT4, SOX2, and NANOG proteins collectively bind to a DNA site in the first intron of the *Xist* gene, followed by the suppression of its transcription



**Fig. 4.** Scheme of the mouse *Xist/Tsix* locus with the binding sites of OCT4, SOX2, and NANOG, and YY1 and CTCF proteins interacting with these transcription factors. *Xist* and *Tsix* exons are indicated by blue and green rectangles, respectively. The red rectangle represents enhancer *Xite*. Arrows indicate the directions of gene transcription.

in undifferentiated mESCs (Fig. 4). Reversible, limited activation of the *Xist* gene is observed in ESCs bearing a homozygous mutation of the *Nanog* gene, while normal binding of OCT4 and SOX2 proteins occurs with the first intron of *Xist*. Repression of all three factors—OCT4, SOX2, and NANOG—is accompanied by rapid accumulation of *Xist* RNA in ESC nuclei. Thus, the factors of pluripotency can directly repress the *Xist* gene via a *Tsix*-independent mechanism.

However, OCT4 and SOX2 have been shown to participate in *Xist* gene regulation via activation of its repressors, *Tsix* and *Xite* [156] (Fig. 4). A bioinformatic analysis has revealed one site for SOX2 binding and two sites for OCT4 binding in the inactivation center of the murine X-chromosome. One site of OCT4 binding is mapped to the vicinity of the CTCF and YY1 (E site) binding sites, at a distance of 1 kb from the *DXPas34* regulatory element, which also contains several sites for CTCF and YY1 binding (D site). A composite site for the binding of the OCT4 and SOX2 transcription factors was found within the region of 1.2 kb, which is known as the *Xite* enhancer (Fig. 4). The fact of OCT4 binding with the sequence of the E site, as well as the OCT4 and SOX2 factors binding to the *Xite* nucleotide sequence, was confirmed *in vitro* by gel-retardation and *in vivo* by chromatin immunoprecipitation methods. The *Xite* enhancer region containing the native OCT4 and SOX2 sites can substantially enhance the activity of the major promoter of the *Tsix* gene within the luciferase reporter gene constructs temporarily transfected into mESCs. Mutations in the OCT4 and SOX2 sites substantially decrease the capability of the *Xite* enhancer of *Tsix* promoter activation. Suppression of *Oct4* gene expression by RNA-interference causes a substantial decrease in the levels of *Tsix* and *Xite* RNA in female-derived mESCs. Suppression of *Sox2* expression also slightly increased the levels of *Tsix* and *Xite* RNA. Apparently, SOX2 plays a substantially less significant role in *Tsix* transactivation, compared to OCT4.

Apart from protein-DNA interactions, the transcription factors OCT4 and SOX2 are characterized by protein-protein interactions, which are directly associated with the X-chromosome inactivation process: OCT4 interacts with the CTCF protein, while SOX2 interacts with the YY1 protein (Fig. 4). It was shown earlier that CTCF and its cofactor YY1 are involved in X-chromosome pairing at the stages of counting and choosing of the future inactive chromosomes. Suppression of *Oct4* expression in mESCs disturbs the X-chromosome pairing in the same way as was observed under *Ctcf* repression, where the fall in the level of *Sox2* expression has no significant effect on this process. Aberrant biallelic *Xist* expression was observed during the formation of embryoid bodies from ESCs, with suppressed *Oct4* expression; this might be a result of the impairment of the X-chromosome counting process. Biallelic expression of *Xist* was not observed under suppression of *Ctcf* and *Sox2* expression [156].

Taking into account the data in the two studies mentioned above, one could assume that OCT4 regulates the *Xist* gene in two ways: direct repression – together with SOX2 and NANOG – of *Xist* transcription and activation of the *Tsix* gene. During cell differentiation, the OCT4 factor, in cooperation with CTCF, mediates normal X-chromosome pairing in the *Tsix/Xite* region, providing counting and choice of the future active and inactive X-chromosomes. The decrease in the *Oct4* gene transcription level results in the loss of OCT4 binding with one of the X-chromosomes, repression of *Tsix*, and activation of *Xist*, and it is the chromosome that becomes inactive. Yet, the residual amount of OCT4 in the coming active X-chromosome supports *Tsix* expression and *Xist* repression. This model very elegantly represents the association between pluripotency and the status of the X-chromosome in the cells of female mammals. However, a number of unanswered questions still remain. For instance, how is the difference in the binding force or in the amounts of OCT4, SOX2,

and NANOG in the coming active and inactive X-chromosomes achieved during differentiation. Logically, one should expect that, under random X-chromosome inactivation, this is a random process as well. But the question of what happens with imprinted inactivation when only a male-derived X-chromosome becomes inactive arises. Active and inactive X-chromosomes are genetically equivalent; meaning that the difference in protein binding cannot be ascribed to the difference in nucleotide sequences. There is an evident need for a search for additional protein molecules or epigenetic factors capable of modulating this process.

Another interesting question is associated with the status of the X-chromosome in human ESCs. The first produced hESC line (H9) possessed two active X-chromosomes, as was observed in mESCs [15, 157], and was devoid of *XIST* gene transcription. Random inactivation of one of the X-chromosome and an increase in *XIST* expression were observed during H9 differentiation. However, it was found later that several H9 subclones had the ability to express *XIST*, whose RNA covers the inactive chromosome even in nondifferentiated cells [158]. Moreover, other hESC lines were found to express *XIST* and to bear the inactive X-chromosome [157–159]. The data published by the International Consortium of Stem Cell Networks demonstrates that about half of the analyzed ESC lines produced in different laboratories express the *XIST* gene, simultaneously with pluripotency markers, such as OCT4, SOX2, and NANOG [159]. The analysis of eleven human ESC lines carried out by Silva and associates [160] has enabled to separate ESC into three groups: 1) cells with two active X-chromosomes, one of which is inactivated during the

differentiation process; 2) cells with one inactive chromosome in both the undifferentiated and differentiated states; and 3) cells which do not express *XIST* in both the undifferentiated and differentiated states [160]. Further experiments have shown that, in spite of the lack of *XIST* transcription, the cells belonging to the third group have an inactive X-chromosome [160]. All of the examples given above suggest that, in humans, *XIST* transcription and X-chromosome inactivation are not directly associated with pluripotency and the activity of OCT4, SOX2, and NANOG.

### CONCLUSION

Embryonic stem cells are a unique object for fundamental and applied studies. Their uniqueness is rooted in two of their properties – self-renewal and pluripotency. Modern methods in cell biology and molecular genetic analysis have allowed to look anew at the molecular basis of and factors controlling self-renewal and pluripotency. The basic properties of embryonic stem cells are determined by a complex multicomponent system including transcription factors, signaling cascades, as well as a system of epigenetic regulation and miRNAs. Certainly, the obtained information will help to better understand the nature of many processes occurring in the embryogenesis of animals, including humans. Additionally, new knowledge will allow a more effective use of ESC in applied research, as well as to understand the causes behind many inherited human diseases and facilitate the development of therapies. ●

*This work was supported by the Program of the RAS Presidium Molecular and Cellular Biology.*

### REFERENCES

1. Surani M.A., Hayashi K., Hajkova P. // *Cell*. 2007. V. 128. P. 747–762.
2. Jaenisch R., Young R. // *Cell*. 2008. V. 132. P. 567–582.
3. Durcova-Hills G., Ainscough J., McLaren A. // *Differentiation*. 2001. V. 68. P. 220–226.
4. McLaren A., Durcova-Hills G. // *Reprod. Fertil. Dev.* 2001. V. 13. P. 661–664.
5. Tesar P.J., Chenoweth J.G., Brook F.A., et al. // *Nature*. 2007. V. 448. P. 196–199.
6. Takahashi K., Yamanaka S. // *Cell*. 2006. V. 126. P. 663–676.
7. Takahashi K., Tanabe K., Ohnuki M., et al. // *Cell*. 2007. V. 131. P. 861–872.
8. Wernig M., Meissner A., Foreman R., et al. // *Nature*. 2007. V. 448. P. 318–324.
9. Johnson M.H., Ziomek C.A. // *Cell*. 1981. V. 24. P. 71–80.
10. Zernicka-Goetz M. // *Nat. Rev. Mol. Cell Biol.* 2005. V. 6. P. 919–928.
11. Rossant J. // *Cell*. 2009. V. 138. P. 1047–1050.
12. Evans M.J., Kaufman M.H. // *Nature*. 1981. V. 292. P. 154–156.
13. Martin G.R. // *Proc. Natl. Acad. Sci. USA*. 1981. V. 78. P. 7634–7638.
14. Thomson A., Wojtacha D., Hewitt Z., et al. // *Cloning Stem Cells*. 2008. V. 10. P. 89–106.
15. Thomson J.A., Itskovitz-Eldor J., Shapiro S.S., et al. // *Science*. 1998. V. 282. P. 1145–1147.
16. Tanaka S., Kunath T., Hadjantonakis A.K., et al. // *Science*. 1998. V. 282. P. 2072–2075.
17. Kunath T., Arnaud D., Uy G.D., et al. // *Development*. 2005. V. 132. P. 1649–1661.
18. Shevchenko A.I., Demina V.V., Mazurok N.A., et al. // *Rus. J. Genetics*. 2008. V. 44. P. 1280–1289.
19. Xu R.H., Chen X., Li D.S., et al. // *Nat. Biotechnol.* 2002. V. 20. P. 1261–1264.
20. Xu R.H., Peck R.M., Li D.S., et al. // *Nat. Methods*. 2005. V. 2. P. 185–190.
21. Humphrey R.K., Beattie G.M., Lopez A.D., et al. // *Stem Cells*. 2004. V. 22. P. 522–530.
22. Boyer L.A., Lee T.I., Cole M.F., et al. // *Cell*. 2005. V. 122. P. 947–956.
23. Loh Y.H., Wu Q., Chew J.L., et al. // *Nat. Genet.* 2006. V. 38. P. 431–440.
24. Niwa H., Ogawa K., Shimosato D., Adachi K. // *Nature*. 2009. V. 460. P. 118–122.
25. Burdon T., Chambers I., Stracey C., et al. // *Cells Tissues Organs*. 1999. V. 165. P. 131–143.

## REVIEWS

26. Smith A.G., Heath J.K., Donaldson D.D., et al. // *Nature*. 1988. V. 336. P. 688–690.
27. Williams R.L., Hilton D.J., Pease S., et al. // *Nature*. 1988. V. 336. P. 684–687.
28. Niwa H., Burdon T., Chambers I., Smith A. // *Genes Dev*. 1998. V. 12. P. 2048–2060.
29. Matsuda T., Nakamura T., Nakao K., et al. // *EMBO J*. 1999. V. 18. P. 4261–4269.
30. Sumi T., Fujimoto Y., Nakatsuji N., Suemori H. // *Stem Cells*. 2004. V. 22. P. 861–872.
31. Shi Y., Massague J. // *Cell*. 2003. V. 113. P. 685–700.
32. James D., Levine A.J., Besser D., Hemmati-Brivanlou A. // *Development*. 2005. V. 132. P. 1273–1282.
33. Vallier L., Reynolds D., Pedersen R.A. // *Dev. Biol*. 2004. V. 275. P. 403–421.
34. Vallier L., Alexander M., Pedersen R.A. // *J. Cell Sci*. 2005. V. 118. P. 4495–4509.
35. Assou S., Le Carrour T., Tondeur S., et al. // *Stem Cells*. 2007. V. 25. P. 961–973.
36. Xiao L., Yuan X., Sharkis S.J. // *Stem Cells*. 2006. V. 24. P. 1476–1486.
37. Greber B., Lehrach H., Adjaye J. // *Stem Cells*. 2007. V. 25. P. 455–464.
38. Chen C., Ware S.M., Sato A., et al. // *Development*. 2006. V. 133. P. 319–329.
39. Levine A.J., Brivanlou A.H. // *Cell Cycle*. 2006. V. 5. P. 1069–1073.
40. Ying Q.L., Nichols J., Chambers I., Smith A. // *Cell*. 2003. V. 115. P. 281–292.
41. Amit M., Carpenter M.K., Inokuma M.S., et al. // *Dev. Biol*. 2000. V. 227. P. 271–278.
42. Hamazaki T., Kehoe S.M., Nakano T., Terada N. // *Mol. Cell. Biol*. 2006. V. 26. P. 7539–7549.
43. Dvorak P., Dvorakova D., Koskova S., et al. // *Stem Cells*. 2005. V. 23. P. 1200–1211.
44. Dvorak P., Hampl A. // *Folia Histochem. Cytobiol*. 2005. V. 43. P. 203–208.
45. Aubert J., Dunstan H., Chambers I., Smith A. // *Nat. Biotechnol*. 2002. V. 20. P. 1240–1245.
46. Sato N., Meijer L., Skaltsounis L., et al. // *Nat. Med*. 2004. V. 10. P. 55–63.
47. Dravid G., Ye Z., Hammond H., et al. // *Stem Cells*. 2005. V. 23. P. 1489–1501.
48. Lu J., Hou R., Booth C.J., et al. // *Proc. Natl. Acad. Sci. USA*. 2006. V. 103. P. 5688–5693.
49. Okamoto K., Okazawa H., Okuda A., et al. // *Cell*. 1990. V. 60. P. 461–472.
50. Rosner M.H., Vigano M.A., Ozato K., et al. // *Nature*. 1990. V. 345. P. 686–692.
51. Scholer H.R., Balling R., Hatzopoulos A.K., et al. // *EMBO J*. 1989. V. 8. P. 2551–2557.
52. Palmieri S.L., Peter W., Hess H., Scholer H.R. // *Dev. Biol*. 1994. V. 166. P. 259–267.
53. Nichols J., Zevnik B., Anastassiadis K., et al. // *Cell*. 1998. V. 95. P. 379–391.
54. Kirchhof N., Carnwath J.W., Lemme E., et al. // *Biol. Reprod*. 2000. V. 63. P. 1698–1705.
55. Hansis C., Grifo J.A., Krey L.C. // *Mol. Hum. Reprod*. 2000. V. 6. P. 999–1004.
56. Mitalipov S.M., Kuo H.C., Hennebold J.D., Wolf D.P. // *Biol. Reprod*. 2003. V. 69. P. 1785–1792.
57. Cauffman G., van de Velde H., Liebaers I., van Steirteghem A. // *Mol. Hum. Reprod*. 2005. V. 11. P. 173–181.
58. Niwa H., Miyazaki J., Smith A.G. // *Nat. Genet*. 2000. V. 24. P. 372–376.
59. Kehler J., Tolkunova E., Koschorz B., et al. // *EMBO Rep*. 2004. V. 5. P. 1078–1083.
60. Velkey J.M., O'Shea K.S. // *Genesis*. 2003. V. 37. P. 18–24.
61. Hay D.C., Sutherland L., Clark J., Burdon T. // *Stem Cells*. 2004. V. 22. P. 225–235.
62. Takeda J., Seino S., Bell G.I. // *Nucl. Acids Res*. 1992. V. 20. P. 4613–4620.
63. van Eijk M.J., van Rooijen M.A., Modina S., et al. // *Biol. Reprod*. 1999. V. 60. P. 1093–1103.
64. Nordhoff V., Hubner K., Bauer A., et al. // *Mamm. Genome*. 2001. V. 12. P. 309–317.
65. Medvedev S.P., Shevchenko A.I., Elisaphenko E.A., et al. // *BMC Genomics*. 2008. V. 9. P. 162.
66. Yeom Y.I., Ha H.S., Balling R., et al. // *Mech. Dev*. 1991. V. 35. P. 171–179.
67. Atlasi Y., Mowla S.J., Ziaee S.A., et al. // *Stem Cells*. 2008. V. 26. P. 3068–3074.
68. Lee J., Kim H.K., Rho J.Y., et al. // *J. Biol. Chem*. 2006. V. 281. P. 33554–33565.
69. Cauffman G., Liebaers I., van Steirteghem A., van de Velde H. // *Stem Cells*. 2006. V. 24. P. 2685–2691.
70. Wang X., Zhao Y., Xiao Z., et al. // *Stem Cells*. 2009. V. 27. P. 1265–1275.
71. Wang S.H., Tsai M.S., Chiang M.F., Li H. // *Gene Expr. Patterns*. 2003. V. 3. P. 99–103.
72. Chambers I., Colby D., Robertson M., et al. // *Cell*. 2003. V. 113. P. 643–655.
73. Mitsui K., Tokuzawa Y., Itoh H., et al. // *Cell*. 2003. V. 113. P. 631–642.
74. Hyslop L., Stojkovic M., Armstrong L., et al. // *Stem Cells*. 2005. V. 23. P. 1035–1043.
75. Pan G.J., Pei D.Q. // *Cell Res*. 2003. V. 13. P. 499–502.
76. Pan G., Pei D. // *J. Biol. Chem*. 2005. V. 280. P. 1401–1407.
77. Mullin N.P., Yates A., Rowe A.J., et al. // *Biochem. J*. 2008. V. 411. P. 227–231.
78. Wang J., Levasseur D.N., Orkin S.H. // *Proc. Natl. Acad. Sci. USA*. 2008. V. 105. P. 6326–6331.
79. Wang Z., Ma T., Chi X., Pei D. // *J. Biol. Chem*. 2008. V. 283. P. 4480–4489.
80. Medvedev S.P., Elisaphenko E.A., Shevchenko A.I., et al. // *Dokl. Biochem. Biophys*. 2009. V. 425. P. 102–105.
81. Avilion A.A., Nicolis S.K., Pevny L.H., et al. // *Genes Dev*. 2003. V. 17. P. 126–140.
82. Masui S., Nakatake Y., Toyooka Y., et al. // *Nat. Cell Biol*. 2007. V. 9. P. 625–635.
83. Adachi K., Suemori H., Yasuda S.Y., et al. // *Genes Cells*. 2010. V. 15. P. 455–470.
84. Botquin V., Hess H., Fuhrmann G., et al. // *Genes Dev*. 1998. V. 12. P. 2073–2090.
85. Yuan H., Corbi N., Basilico C., Dailey L. // *Genes Dev*. 1995. V. 9. P. 2635–2645.
86. Nishimoto M., Fukushima A., Okuda A., Muramatsu M. // *Mol. Cell. Biol*. 1999. V. 19. P. 5453–5465.
87. Liu L., Roberts R.M. // *J. Biol. Chem*. 1996. V. 271. P. 16683–16689.
88. Liu L., Leaman D., Villalta M., Roberts R.M. // *Mol. Endocrinol*. 1997. V. 11. P. 1651–1658.
89. Pesce M., Scholer H.R. // *Mol. Reprod. Dev*. 2000. V. 55. P. 452–457.
90. Ambrosetti D.C., Basilico C., Dailey L. // *Mol. Cell. Biol*. 1997. V. 17. P. 6321–6329.
91. Tomilin A., Remenyi A., Lins K., et al. // *Cell*. 2000. V. 103. P. 853–864.
92. Remenyi A., Tomilin A., Pohl E., et al. // *Mol. Cell*. 2001. V. 8. P. 569–580.



## REVIEWS

93. Kang J., Gemberling M., Nakamura M., et al. // *Genes Dev.* 2009. V. 23. P. 208–222.
94. Abeyta M.J., Clark A.T., Rodriguez R.T., et al. // *Hum. Mol. Genet.* 2004. V. 13. P. 601–608.
95. Brandenberger R., Khrebtukova I., Thies R.S., et al. // *BMC Dev. Biol.* 2004. V. 4. P. 10.
96. Catena R., Tiveron C., Ronchi A., et al. // *J. Biol. Chem.* 2004. V. 279. P. 41846–41857.
97. Kuroda T., Tada M., Kubota H., et al. // *Mol. Cell. Biol.* 2005. V. 25. P. 2475–2485.
98. Niwa H. // *Cell Struct. Funct.* 2001. V. 26. P. 137–148.
99. Okumura-Nakanishi S., Saito M., Niwa H., Ishikawa F. // *J. Biol. Chem.* 2005. V. 280. P. 5307–5317.
100. Rodda D.J., Chew J.L., Lim L.H., et al. // *J. Biol. Chem.* 2005. V. 280. P. 24731–24737.
101. Sato N., Sanjuan I.M., Heke M., et al. // *Dev. Biol.* 2003. V. 260. P. 404–413.
102. Wei C.L., Miura T., Robson P., et al. // *Stem Cells.* 2005. V. 23. P. 166–185.
103. Chew J.L., Loh Y.H., Zhang W., et al. // *Mol. Cell. Biol.* 2005. V. 25. P. 6031–6046.
104. Suzuki A., Raya A., Kawakami Y., et al. // *Proc. Natl. Acad. Sci. USA.* 2006. V. 103. P. 10294–10299.
105. Wang J., Rao S., Chu J., et al. // *Nature.* 2006. V. 444. P. 364–368.
106. Wu Q., Chen X., Zhang J., et al. // *J. Biol. Chem.* 2006. V. 281. P. 24090–24094.
107. Pardo M., Lang B., Yu L., et al. // *Cell Stem Cell.* 2010. V. 6. P. 382–395.
108. van den Berg D.L., Snoek T., Mullin N.P., et al. // *Cell Stem Cell.* 2010. V. 6. P. 369–381.
109. Hatano S.Y., Tada M., Kimura H., et al. // *Mech. Dev.* 2005. V. 122. P. 67–79.
110. Lauberth S.M., Rauchman M. // *J. Biol. Chem.* 2006. V. 281. P. 23922–23931.
111. Korutla L., Wang P.J., Mackler S.A. // *J. Neurochem.* 2005. V. 94. P. 786–793.
112. Tomioka M., Nishimoto M., Miyagi S., et al. // *Nucleic Acids Res.* 2002. V. 30. P. 3202–3213.
113. Brehm A., Ohbo K., Zwerschke W., et al. // *Mol. Cell. Biol.* 1999. V. 19. P. 2635–2643.
114. Guo Y., Costa R., Ramsey H., et al. // *Proc. Natl. Acad. Sci. USA.* 2002. V. 99. P. 3663–3667.
115. Tolkunova E., Malashicheva A., Parfenov V.N., et al. // *J. Mol. Biol.* 2007. V. 374. P. 1200–1212.
116. Webster D.M., Teo C.F., Sun Y., et al. // *BMC Dev. Biol.* 2009. V. 9. P. 28.
117. Bernstein B.E., Mikkelsen T.S., Xie X., et al. // *Cell.* 2006. V. 125. P. 315–326.
118. Ringrose L., Paro R. // *Annu. Rev. Genet.* 2004. V. 38. P. 413–443.
119. O'Carroll D., Erhardt S., Pagani M., et al. // *Mol. Cell. Biol.* 2001. V. 21. P. 4330–4336.
120. Pasini D., Bracken A.P., Jensen M.R., et al. // *EMBO J.* 2004. V. 23. P. 4061–4071.
121. Shumacher A., Faust C., Magnuson T. // *Nature.* 1996. V. 383. P. 250–253.
122. Voncken J.W., Roelen B.A., Roefs M., et al. // *Proc. Natl. Acad. Sci. USA.* 2003. V. 100. P. 2468–2473.
123. Boyer L.A., Plath K., Zeitlinger J., et al. // *Nature.* 2006. V. 441. P. 349–353.
124. Lee T.I., Jenner R.G., Boyer L.A., et al. // *Cell.* 2006. V. 125. P. 301–313.
125. Chamberlain S.J., Yee D., Magnuson T. // *Stem Cells.* 2008. V. 26. P. 1496–1505.
126. Woolfe A., Goodson M., Goode D.K., et al. // *PLoS Biol.* 2005. V. 3. P. e7.
127. Ura H., Usuda M., Kinoshita K., et al. // *J. Biol. Chem.* 2008. V. 283. P. 9713–9723.
128. Addis R.C., Prasad M., Yochem R.L., et al. // *J. Cell. Biochem.* 2010. [Epub ahead of print]
129. Feldman N., Gerson A., Fang J., et al. // *Nat. Cell Biol.* 2006. V. 8. P. 188–194.
130. Gaspar-Maia A., Alajem A., Polesso F., et al. // *Nature.* 2009. V. 460. P. 863–868.
131. Chen X., Xu H., Yuan P., et al. // *Cell.* 2008. V. 133. P. 1106–1117.
132. Huangfu D., Maehr R., Guo W., et al. // *Nat. Biotechnol.* 2008. V. 26. P. 795–797.
133. Huangfu D., Osafune K., Maehr R., et al. // *Nat. Biotechnol.* 2008. V. 26. P. 1269–1275.
134. Shi Y., Despons C., Do J.T., et al. // *Cell Stem Cell.* 2008. V. 3. P. 568–574.
135. Shi Y., Do J.T., Despons C., et al. // *Cell Stem Cell.* 2008. V. 2. P. 525–528.
136. Mikkelsen T.S., Hanna J., Zhang X., et al. // *Nature.* 2008. V. 454. P. 49–55.
137. Hattori N., Nishino K., Ko Y.G., et al. // *J. Biol. Chem.* 2004. V. 279. P. 17063–17069.
138. Hattori N., Imao Y., Nishino K., et al. // *Genes Cells.* 2007. V. 12. P. 387–396.
139. Bernstein E., Kim S.Y., Carmell M.A., et al. // *Nat. Genet.* 2003. V. 35. P. 215–217.
140. Kanellopoulou C., Muljo S.A., Kung A.L., et al. // *Genes Dev.* 2005. V. 19. P. 489–501.
141. Murchison E.P., Partridge J.F., Tam O.H., et al. // *Proc. Natl. Acad. Sci. USA.* 2005. V. 102. P. 12135–12140.
142. Wang Y., Medvid R., Melton C., et al. // *Nat. Genet.* 2007. V. 39. P. 380–385.
143. Marson A., Levine S.S., Cole M.F., et al. // *Cell.* 2008. V. 134. P. 521–533.
144. Tay Y., Zhang J., Thomson A.M., et al. // *Nature.* 2008. V. 455. P. 1124–1128.
145. Tay Y.M., Tam W.L., Ang Y.S., et al. // *Stem Cells.* 2008. V. 26. P. 17–29.
146. Wellner U., Schubert J., Burk U.C., et al. // *Nat. Cell Biol.* 2009. V. 11. P. 1487–1495.
147. Xu N., Papagiannakopoulos T., Pan G., et al. // *Cell.* 2009. V. 137. P. 647–658.
148. Judson R.L., Babiarz J.E., Venere M., Blueloch R. // *Nat. Biotechnol.* 2009. V. 27. P. 459–461.
149. Yu J., Vodyanik M.A., Smuga-Otto K., et al. // *Science.* 2007. V. 318. P. 1917–1920.
150. Chureau C., Prissette M., Bourdet A., et al. // *Genome Res.* 2002. V. 12. P. 894–908.
151. Brockdorff N., Ashworth A., Kay G.F., et al. // *Cell.* 1992. V. 71. P. 515–526.
152. Lee J.T., Davidow L.S., Warshawsky D. // *Nat. Genet.* 1999. V. 21. P. 400–404.
153. Lee J.T., Lu N. // *Cell.* 1999. V. 99. P. 47–57.
154. Wutz A., Jaenisch R. // *Mol. Cell.* 2000. V. 5. P. 695–705.
155. Navarro P., Chambers I., Karwacki-Neisius V., et al. // *Science.* 2008. V. 321. P. 1693–1695.
156. Donohoe M.E., Silva S.S., Pinter S.F., et al. // *Nature.* 2009. V. 460. P. 128–132.
157. Dhara S.K., Benvenisty N. // *Nucleic Acids Res.* 2004. V. 32. P. 3995–4002.
158. Hoffman L.M., Hall L., Batten J.L., et al. // *Stem Cells.* 2005. V. 23. P. 1468–1478.
159. Adewumi O., Aflatoonian B., Ahrlund-Richter L., et al. // *Nat. Biotechnol.* 2007. V. 25. P. 803–816.
160. Silva S.S., Rowntree R.K., Mekhoubad S., Lee J.T. // *Proc. Natl. Acad. Sci. USA.* 2008. V. 105. P. 4820–4825.